

Package consists of: Base, Wedge, Slide, Angle Pin and Slide Lock

**Materials:** Wedge: S7 Rc 54-60; Base: Aluminum Bronze; Machinable Slide: 4140 Rc 28-30; Base Slide: 4140 Rc 28-30

**Tolerances:** +/- .005 unless; otherwise indicated

Catalog Number		Max Stroke	L +000 -.005	W +000 -.005	Ws +000 -.001	A	B	C +001 -.000	D	E	F	Ls	G
w/Finished Slide	w/Machinable Slide												
GSA5-16B	GSA5-16M	.6	2.000	1.500	.625	1.110	1.380	.626	.600	1.115	.690	1.384	1.125
GSA5-20B	GSA5-20M	1.0	2.800	1.500	.625	1.510	1.780	.626	.600	1.515	1.090	1.784	1.525
GSA8-20B	GSA8-20M	1.0	2.800	1.875	1.000	1.510	1.780	1.001	.975	1.515	1.090	1.784	1.525
GSA11-20B	GSA11-20M	1.0	2.800	2.250	1.375	1.510	1.780	1.376	1.350	1.515	1.090	1.784	1.525

- Small footprint slide assembly
- Complete and ready to install
- Optional *machinable* slide

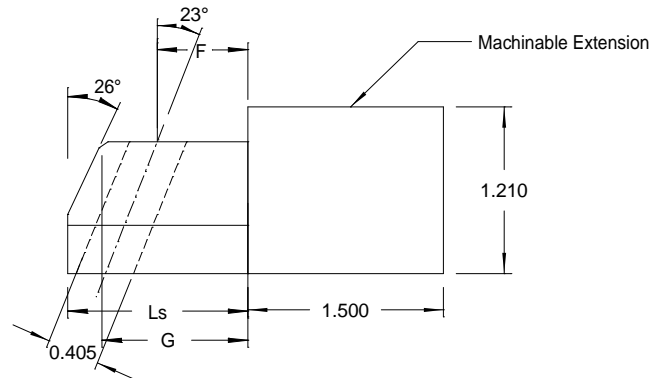
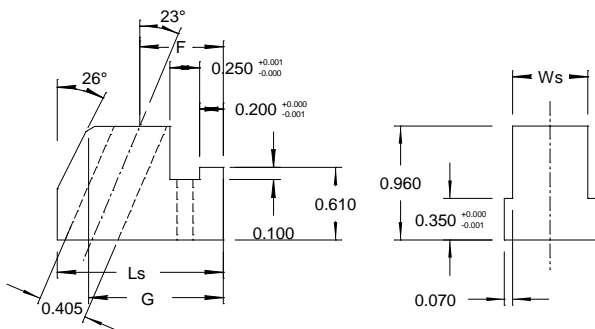
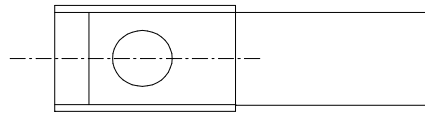
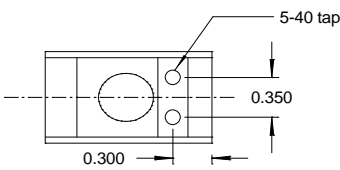
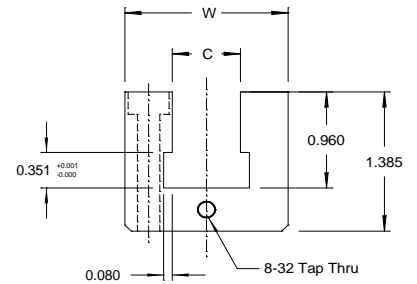
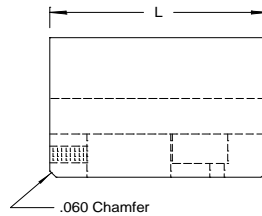
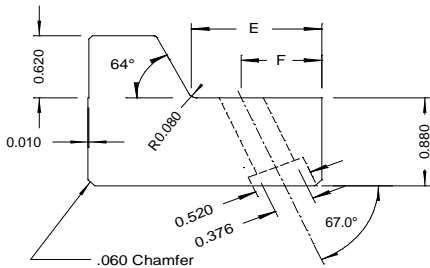
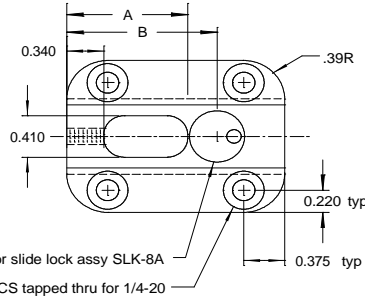
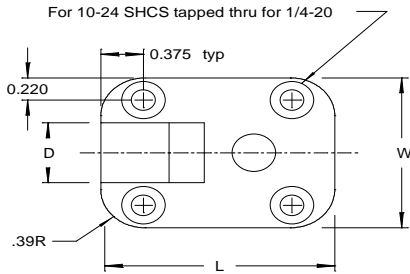

Basic Slide Material: 4140 Rc 28 - 30